



Industry 4.0

The WÖHWA Belt Scale SFB 22 is technically equipped for complete integration into a control system concept that meets the requirements of Industry 4.0 in every aspect. The use of the Condition Monitoring System makes the changeover to continuous online measurements possible. Reliable weighing data and the operational state of the device are provided in real time.

- Device settings can be modified on any standard PC via Web Server.
- Remote diagnosis and maintenance via internet
- Access from any network/intranet PC via IP address
- Error display and troubleshooting via remote maintenance
- All belt scale parameters can be set via internet

Accuracy

The Belt Scale SFB 22 exceeds all previous, commercially available standards in respect of accuracy by using load cells that were engineered in cooperation with Mettler-Toledo.

- The maximum combined error during measurements is 0.0018 % of the nominal load capacity. For an SSH 200-kg load cell this results in a maximum deviation from the measured weight of 0.0036 kg.
- The measurement error in percent, depending upon the flow rate, is 0.01 %. (without influences caused by mechanical properties).
- The verifiable repeatability of the rated output is 0.01 % and exceeds the accuracy of all commercially available belt scale systems.

Help

A free questionnaire is available on the WÖHWA home page for identifying detrimental influences

Run Detect

The Run Detect technology signals the belt scale whether the belt is running or not. The Belt Scale SFB 22 determines the flow rate and the conveyed quantity on the basis of the load measured on the weighing section. A constant belt speed is a precondition.

- The electronic system uses a fixed and defined belt speed for processing. Start-up / operation of the conveyor belt is detected by means of an errorproof vibration measurement (no moving parts).
- A measuring wheel can be easily retrofitted using a plug-in connection.
- Due to the automatic detection of the measuring wheel, speed measuring starts immediately after connection of the wheel ("PLUG AND PLAY"). Additional settings are not required.

Applications

Installation of the factory-assembled and maintenance-free belt scale is very easy. Detailed installation instructions are available from the WÖHWA web site.

www.woehwa.com/de/foerderbandwaage-sfb22.php

Arguments based on experiences

- **CAL-Free** theoretic calibration without weights
- **Worldwide spare parts provisioning** by WÖHWA through Mettler Toledo.
- **Protection against climatic effects**
 - > *Corrosion protection: Galvanization provides long-term protection against climatic effects, such as corrosion.*
 - > *Stainless-Steel Single Point Load Cell*
 - > *Protection degree IP66 for all components*
 - > *For rough environments, the SFB 22 can be optionally supplied with a protective coating in accordance with the prevalent corrosivity/environment categories.*

- **Existing idler station** can be used; just drill two holes and fix bolts.
- **Easy installation** since the product has been pre-assembled at the factory and requires only four bolts for mounting.
- **Reusability:** Due to the calibration feature of the WÖHWA mechanical design, it is possible to transfer the belt scale to another belt conveyor.
- **Pluggable Belt Scale:** At delivery, the SFB 22 is completely pre-wired and only requires the corresponding plugs.
- **Automatic detection of measuring wheel:** The control unit of the SFB 22 automatically detects the optionally available measuring wheel after connection.
- **Easy onsite cabling (to be provided locally):** Only a network cable is required; all belt scales can be connected to a network switch, and only one cable runs to the control cabinet.

Documentation

- **Installation instructions** included
- **Circuit diagram** included
- **Operating instructions** included
- **Inspection certificate of production department** included
- **Video animation on mechanical installation** available on the WÖHWA home page
- **Video animation on electrical connection** available on the WÖHWA home page
- **Belt Load Log Software** available for download on the WÖHWA home page
- **PLC module** automatic in-flight compensation

Adjustments

The documentation and two video animations explain in great detail all steps of the mechanical installation, and how to connect the supplied plugs.

www.woehwa.com/de/foerderbandwaage-sfb22.php

Production Test

- Each belt scale is checked for completeness before shipment.
- All belt scale functions are tested before shipment.
- An inspection certificate is provided for each belt scale.
- The belt scale is statically precalibrated and the nominal load capacity is set for the Single Point Load Cell.

Interference Resistance

The treatment and testing of electromagnetic compatibility (EMC) have become absolutely indispensable as a result of the growing density of components in electronic circuits, the extremely compact design of devices, the fast cycle times and the rising clock rates in microprocessors, the increased linking of systems, and the rapidly growing number of interference sources, such as mobile telephony.

The electronic components of the SFB 22 have been tested in excess of the levels required by the EMC standards and have been designed for roughest environmental conditions.

Belt Scale Options

- **High-Resolution Measuring Wheel**
Belt speed measurement with measuring wheel and incremental encoder transmitting 2640 pulses/m. Smallest changes in belt speed are measured and, therefore, cannot affect the accuracy of the belt scale. This ancillary device is particularly recommended for conveyor operation at low and varying belt speeds of less than 0.2 m/s.
- **Standard Measuring Wheel**
Belt speed measurement with measuring wheel and incremental encoder transmitting 121 pulses/m. Measures variations in belt speed. This ancillary device is particularly recommended for conveyor operation at varying belt speeds.
- **Adapter for Tube Chassis**
Adapter for installing the Belt Scale SFB 22 in conveyor belts with tube chassis.

Two Versions are possible

Depending upon belt or chassis width, either one or two Single Point Load Cells are used.

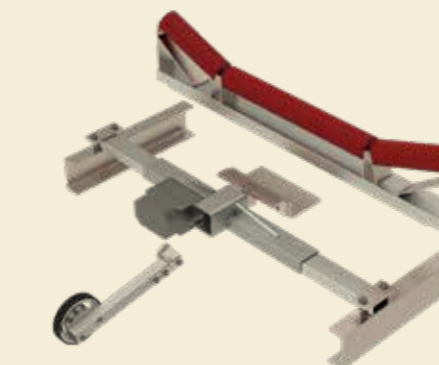

Version 1

Belt speed: 0.5 – 2.0 m/s

Belt width: 500 – 1 000 mm

Chassis width: 630 – 1 400 mm

Number of load stations: 1 station with 1 load cell

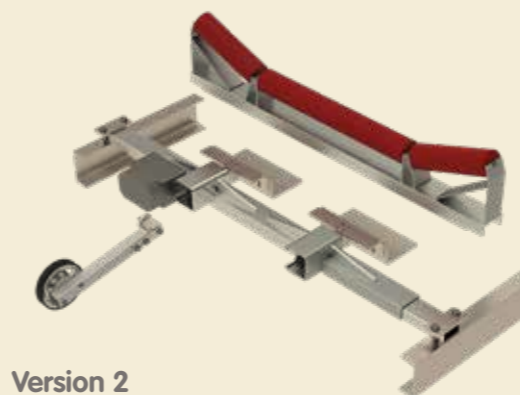

Version 2

Belt speed: 0.5 – 2.0 m/s

Belt width: 1 200 – 1 600 mm

Chassis width: 1 180 – 1 950 mm

Number of load stations: 1 station with 2 load cells

Further versions available upon request.

Single Point Load Cell

The SSH is an extremely robust Single Point Load Cell, suitable for almost any industrial environment.

- No overload protection is required, the SPLC has a breaking load capacity of 300 percent of its nominal load capacity.
- Due to the off-center load compensation, the SSH will weigh within tolerance regardless of the load application point. It can absorb side forces without being destroyed.
- Due to the hermetically sealed housing, the SSH load cell is rated for protection class IP68
- OIML R60 C3 Approval (200 kg)
- Temperature range from -20 °C to +65 °C
- Repeatability of the SPLC's measurement results is ≤ 0.01 % of its nominal rated capacity.
- Error due to the combined effect of non-linearity and hysteresis is ≤ 0.0018% of its nominal rated capacity.

WÖHWA Belt Load Logger

The WÖHWA Belt Load Logger is a software for processing data received from WÖHWA belt scales. It includes all essential features, such as zero setting or resetting the totalizer.

- Graphic display of flow rates.
- Visualization of totalization for each day, week, month, and year.
- The totalization for each day can be divided and assigned to 3 work shifts.
- Stored data can be imported into EXCEL for evaluation.
- Totalling information for each day can be mailed to an e-mail address at a selectable time.
- The software and the operating manual can be downloaded using the following link:
www.woehwa.com/de/foerderbandwaage-sfb22.php

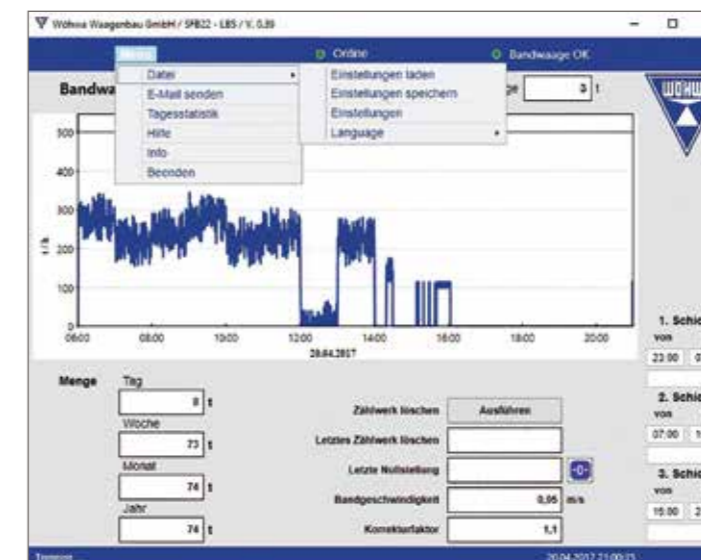

Profinet Interface

Profinet offers users access to data of multivariable devices. Over one single cable, transmission of flow rate, totalizer settings, diagnostic data, etc., is possible.

Weight Transmitter IND141

The Weight Transmitter IND141, used for the SFB 22, is a compact, latest-state-of-the-art unit that offers easy connectivity and has been specially designed and engineered for use in belt scales.

- Supports latest communication protocols for Industrial Ethernet IP, Ethernet TCP IP, and Profinet.
- High-resolution AD converter supporting 100 000 divisions.
- Temperature range from -10 °C to +50 °C
- All belt scale parameters are set via Web Server.
- The Weight Transmitter can be updated via Web Server.
- Approvals: UL, cUL, CE

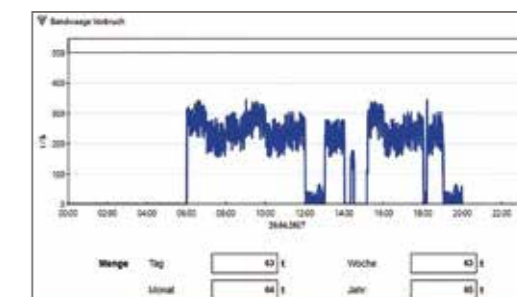



WÖHWA Belt Scale SFB 22

A system for the digital future in the age of Industry 4.0

The new Belt Scale SFB 22 combines tradition and experience in the design and engineering of scales with a view of the digital future within the context of Industry 4.0. In cooperation with Mettler-Toledo, a Single Point Load Cell has been engineered that not only guarantees a high accuracy of measurements, but also facilitates and speeds up transmission of weight data and integration into networks.

Overview of Features and Advantages

✓ Robust Design

The robust design thoroughly protects all relevant parts of the belt scale from climatic effects, making it suitable for use in a variety of different environments and locations. The hermetically sealed stainless-steel load cell, protection class IP68, as well as the galvanized chassis are further features of the rugged design. Operating temperature range from -20 °C to + 65 °C (load cell).

✓ Run Detect

With a constant belt speed, the Run Detect Technology makes a measuring wheel redundant. The SFB 22 detects belt operation by sensing vibrations.

✓ High Breaking Load

The Single Point Load Cell has a breaking load capacity of 300 percent of its nominal load capacity and does not require an overload protection.



✓ Automatic Detection of Measuring Wheel

As an optional add-on, either a standard or a high-resolution measuring wheel can be installed. The SFB 22 automatically detects the optional measuring wheel after it has been installed and connected.

✓ Telescopic Belt Scale

The telescopic belt scale can be easily adapted to varying chassis widths for belt widths ranging from 500 mm to 1 000 mm, using one Single Point Load Cell, or ranging from 1 200 mm to 1 600 mm, using two Single Point Load Cells. Admissible belt speeds up to 2 m/s, further versions for higher belt speeds are available upon request.

✓ Weighing Terminal Not Required

Due to the innovative technology of the measuring unit, no external field display device is required. Operation and monitoring are performed on a PC. Input of Belt Scale settings via WEB Server.

✓ Interfaces

For integration into existing plant systems, standard Ethernet or Profinet interfaces are provided.

✓ Flexible Data Evaluation

The supplied Belt Load Logger provides more functions for the evaluation of weighing data. It is also possible to receive e-mails on the smartphone providing totalling information for each day.



Features / Benefits

- Digital Future within the context of Industry 4.0
- 2 Single Point Load Cells
- Run Detect technology
- No overload protection required
- Temperature range from -20 °C to + 65 °C
- Speed measurement with robust, automatically detected, measuring wheel
- Telescopic chassis
- External configuration via WEB Server
- Ethernet and Profinet interfaces included
- Digital evaluation by E-Mail to smartphone

WÖHWA Belt Scale SFB 22

for belt conveyors with chassis widths of 500 – 1 000 mm and 1 200 to 1 600 mm.

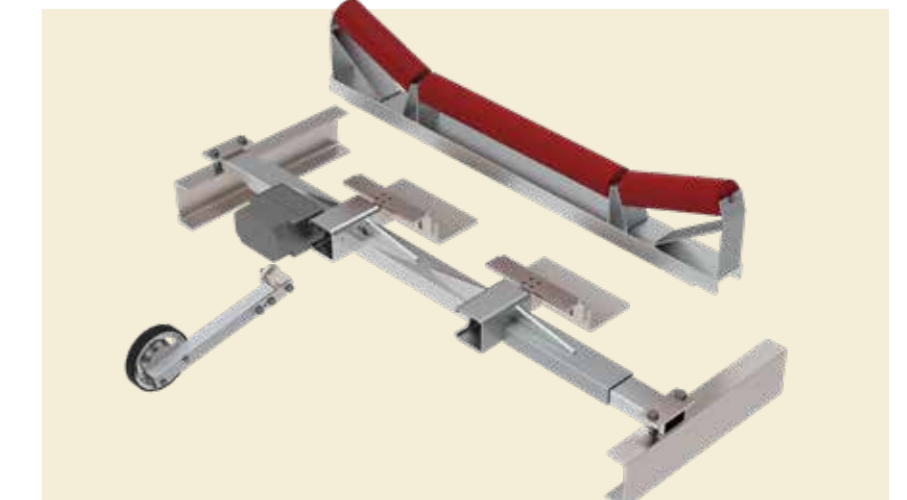
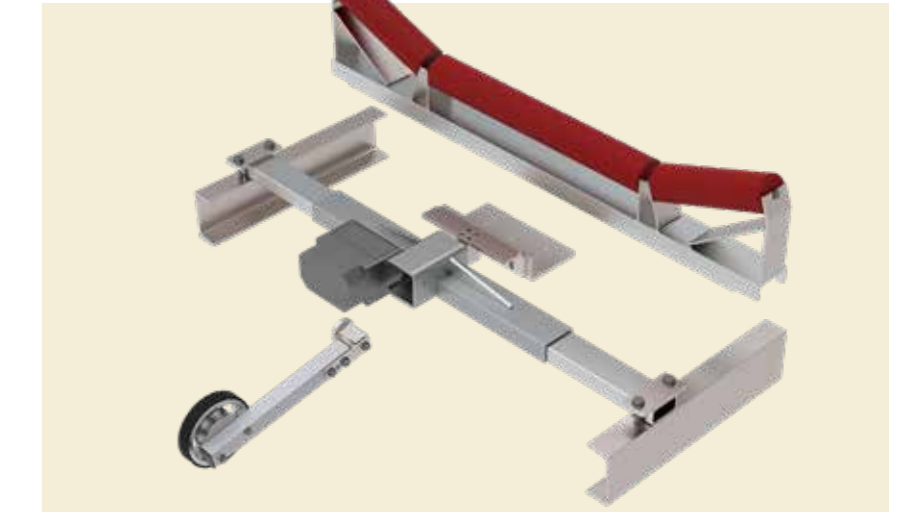

WÖHWA Waagenbau GmbH
 Öhringer Straße 6
 D-74629 Pfedelbach
 Phone +49 (0)7941 9131-0
 Fax +49 (0)7941 9131-28
 info@woehwa.com
 www.woehwa.com